

NOTICE OF PROPRIETARY INFORMATION
 THE INFORMATION CONTAINED IN THIS DRAWING IS THE SOLE PROPERTY OF VIDEORAY, LLC. ANY
 REPRODUCTION IN PART OR AS A WHOLE WITHOUT THE WRITTEN PERMISSION OF VIDEORAY, LLC IS PROHIBITED.

REVISIONS

ZONE	REV.	DESCRIPTION	DATE	APPROVED
---	---	---	---	---
---	---	---	---	---
---	X-01	---	08/04/2021	MW

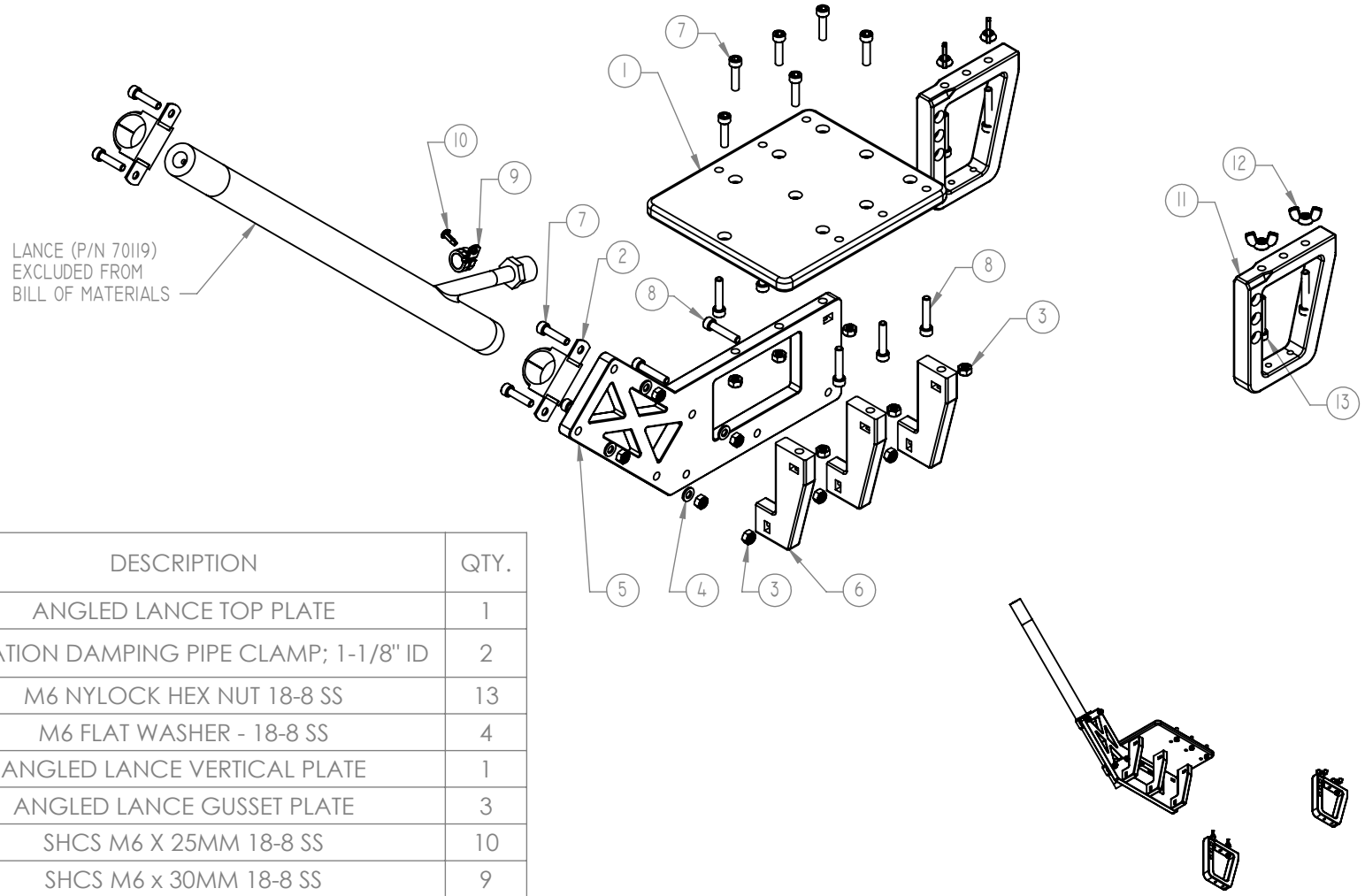

LANCE (P/N 70119)
 EXCLUDED FROM
 BILL OF MATERIALS

ITEM NO.	PART NUMBER	DESCRIPTION	QTY.
1	73434	ANGLED LANCE TOP PLATE	1
2	71875	VIBRATION DAMPING PIPE CLAMP; 1-1/8" ID	2
3	70877	M6 NYLOCK HEX NUT 18-8 SS	13
4	73139	M6 FLAT WASHER - 18-8 SS	4
5	73433	ANGLED LANCE VERTICAL PLATE	1
6	73436	ANGLED LANCE GUSSET PLATE	3
7	71566	SHCS M6 X 25MM 18-8 SS	10
8	71451	SHCS M6 x 30MM 18-8 SS	9
9	71876	VIBRATION DAMPING LOOP CLAMP; 1/2" ID	1
10	70982	PLASTITE #8 x 1/2" 18-8 SS	1
11	73432	STANDOFF; 4.5" LEG HEIGHT; DEFENDER	2
12	71859	WING NUT M6 18-8 SS	4
13	70886	SHCS M6 X 35 MM 18-8 SS	4

	212 EAST HIGH STREET, POTTSTOWN, PA 19464 USATEL: +1 610-458-3000 FAX: +1 610-458-3010 WWW.VIDEORAY.COM	
	TITLE: MSS DEFENDER KIT - CAVIBLASTER LANCE - ANGLED	
DRN: MW 08/04/2021	MATERIAL: ---	SCALE:
CHK: ---	SHEET TITLE: DRAWING	WEIGHT:
APP: ---	REV: X-01 STATUS: DEVELOPMENT	SIZE: A SHEET: 1 OF 2

PLOT DATE: 8/4/2021 1:05:28 PM

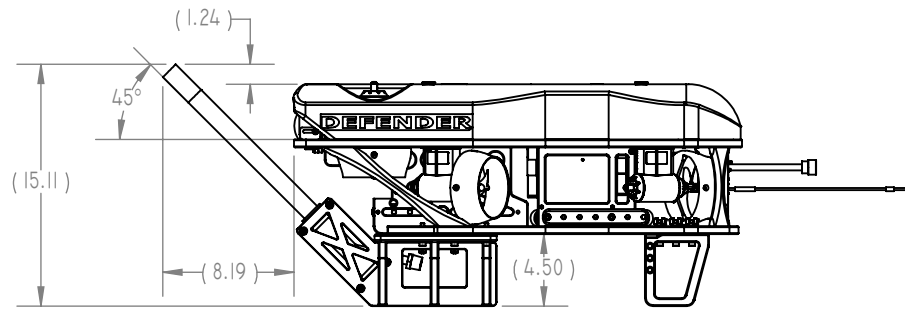
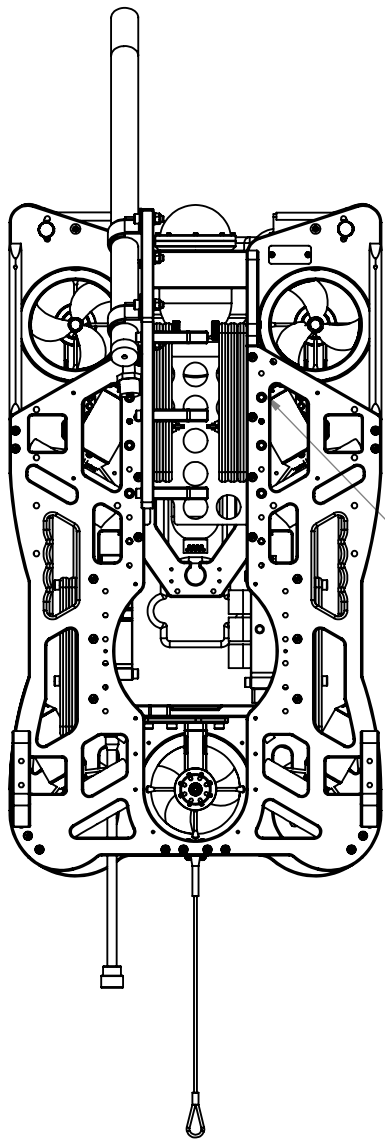

FASTEN THE FRONT HOLE OF THE PLATE (HIDDEN IN THIS VIEW) TO THE HOLE IN THE FRAME NEAREST TO THE FRONT THAT HAS A NUT

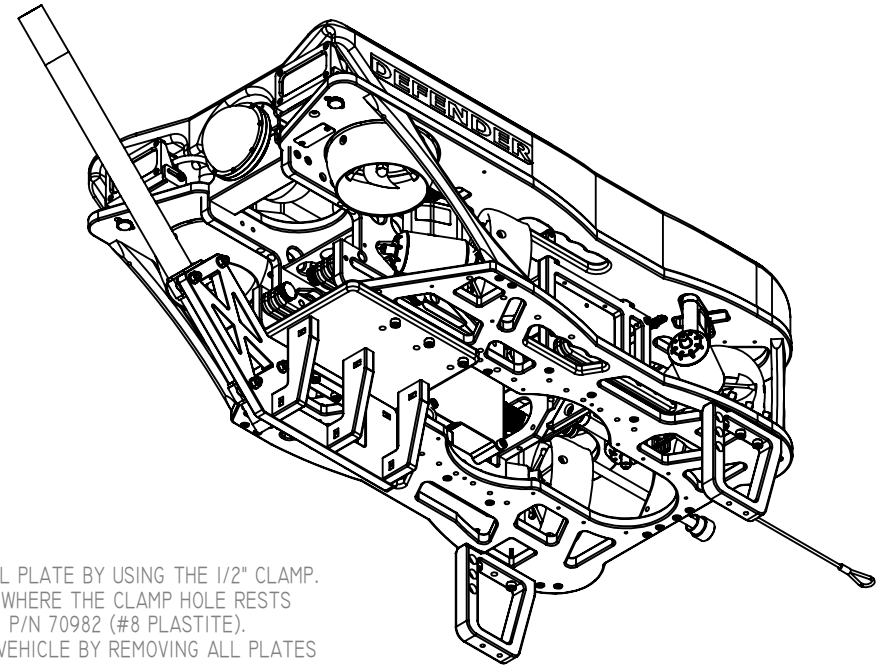

- NOTES:
- 1) SECURE BRANCE OF LANCE TO THE VERTICAL PLATE BY USING THE 1/2" CLAMP. A $\varnothing.125-.156$ " HOLE WILL NEED TO BE DRILLED WHERE THE CLAMP HOLE RESTS AGAINST THE VERTICAL PLATE. FASTEN USING P/N 70982 (#8 PLASTITE).
 - 2) ASSEMBLY CAN GO ON EITHER SIDE OF THE VEHICLE BY REMOVING ALL PLATES FROM TOP PLATE, AND RECONFIGURING THE PLATES ON THE OTHER SIDE.

PLOT DATE: 8/4/2021 1:05:28 PM

		212 EAST HIGH STREET, POTTSTOWN, PA 19464	
		USATEL: +1 610-458-3000 FAX: +1 610-458-3010 WWW.VIDEORAY.COM	
TITLE: MSS DEFENDER KIT - CAVIBLASTER LANCE - ANGLED		PART NO: 71872	
DRN: MW 08/04/2021		MATERIAL: ---	
THIRD ANGLE		SHEET TITLE: SHEET2	
CHK: ---	APP: ---	REV: X-01	STATUS: DEVELOPMENT
		SIZE: A	WEIGHT: ---
		SHEET: 2 OF 2	