



## Schilling Robotics TITAN 4 Manipulator

**We put you first.  
And keep you ahead.**

Thousands of our manipulator systems are in use worldwide every day. TITAN manipulators are the highest quality system on the market for the dexterity and strength needed to withstand the industry's harsh and repetitive needs day after day.

- » Acute Precision Control
- » Durable Through the Harshesht Conditions
- » Reliability Through the Harshesht Conditions
- » Large Operating Envelope
- » High Lift-to-Weight Ratio
- » Depth Rating up to 7,000msw
- » Titanium Construction



The TITAN 4 is widely regarded as the world's premier servo-hydraulic remote manipulator system. Since 1987, these systems have been the industry standard for dexterous manipulator systems used in subsea applications, and are extensively used on ultra-heavy work class ROVs.

This arm has the dexterity and accuracy necessary to perform the fine movements needed for complex tasks. When this ability is combined with the manipulator's reach (1,922mm), payload capacity (122kg at full extension), and large operating envelope, the TITAN 4 offers unequaled performance in a wide range of subsea applications.



In-arm electronics are located in the forearm, increasing system reliability and minimizing electrical connections.

## Acute Precision Control

The manipulator's accuracy is limited only by the pilot's eye. The master controller includes a six-degree-of-freedom replica master arm that ensures comfortable, intuitive manipulator operation. Its movements are just as sharp whether it's moving a 5lb. object or moving a 250lb object.

The controller also contains function keys for selecting menu options and a display for viewing diagnostic and status information. The controller's advanced operational features are individual joint freeze, position scaling (altering the ratio of master arm movement to manipulator arm movement), password security, programmable stow/deploy routines, individual joint movement limits, incremental gripper movement, individual joint diagnostics, and automatic error checking.



The replica master arm ensures comfortable, intuitive operation.

## SPECIFICATIONS

Reach:	1,922mm
Type:	Position Controlled
Functions:	7
Material:	Primarily Titanium

- » **Arm Specifications**
  - Standard Depth: 4,000 msw
  - Extended Depth: 7,000 msw
  - Weight in air: 100kg
  - Weight in water: 78kg
  - Lift at full extension: 122kg
  - Maximum lift, nominal: 454kg
  - Standard Gripper Opening: 99mm
  - Grip Force, nominal: 4,092N
  - Wrist torque, nominal: 170Nm
  - Wrist rotate, cont.: 6-35rpm
- » **Master Controller Specifications**
  - Length: 470mm
  - Width: 177mm
  - Height: 67mm
  - Weight: 3.7kg
- » **Electrical and Telemetry**
  - Input Power, Controller: 90-260VAC
  - Input Power, Arm: 24 VDC
  - Power, Controller: 6W start, 3W run
  - Power, Arm: 6W start, 45W run
  - Telemetry: RS-232 or RS-422/485
- » **Hydraulic Requirements**
  - Fluid: Mineral, Glycol, or Synthetic
  - Viscosity: 10-200 cSt
  - Available Flow: 5.7 - 19 lpm
  - Max. Pressure: 3,000 psi
  - Max. Fluid Temperature: 54°C
  - Fluid Cleanliness: ISO 4406 14/11



Colored diagnostic lights in the connector head indicate the status of electrical power delivery to the arm, master controller transmission to the arm, and arm responsiveness.

## Construction

The arm is constructed primarily of titanium for structural strength, light weight, corrosion resistance, and extraordinary resistance to damage from collisions. TITAN manipulators have a proven track record of reliability in the world's most demanding subsea environments.

## Operating Envelope

It is engineered to give its operators the largest range of motion in its class. This significant flexibility only enhances the arm's precision dexterity for exploration and recovery missions.

## System Reliability

### Robust Power/Signal Connection

A SeaNet cable connects the arm to electrical power and telemetry, providing a robust, reliable attachment. The small diameter cable (8.9mm) is actively pressure balanced and oil filled. The connector head has spring-loaded contacts, and a positive locking feature eliminates accidental cable disconnection.

### Reliable In-Arm Electronics

All downside arm electronics are located inside the manipulator forearm. This configuration greatly reduces the number of electrical connections, simplifying service operations and increasing the system's ability to withstand shock.

### Quick, Easy Diagnostics

The SeaNet cable connector head contains bright LED status indicator lights that allow first-level diagnostics to be performed solely by visual inspection. The lights show that electrical power is being delivered to the arm, that the controller is transmitting to the arm, and that the arm is responding. This information lets the operator quickly determine where to begin troubleshooting, without removing connectors, applying a voltmeter, or opening sealed enclosures. The system also detects missing or reduced arm position sensor signals, and diagnostic lights on the in-arm electronics module indicate system health.



The titanium wrist camera can be ordered already installed on a new TITAN 4 manipulator system.

## Manipulator Compatibility

To create the best manipulators on the market, we took the most field proven manipulator technologies and used them repetitively throughout the system. The result is a simple, reliable system with high component commonality that minimizes spare part requirements. Many parts are interchangeable throughout the entire manipulator line: TITAN 4, ATLAS, RigMaster, CONAN, and ORION.

## Options and Accessories

- » Extended Depth Rating to 7,000msw
- » Spares Kit
- » Seal Installation Tool Kit
- » Technician's Tool Kit
- » Dual-Manipulator Configuration includes two manipulator arms and a single master controller with two replica master arms.
- » Radiation Hardening (up to  $1 \times 10^7$  rad gamma)
- » Titanium Wrist-Mounted Camera

## Gripper Options

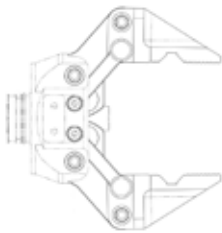

4" Parallel

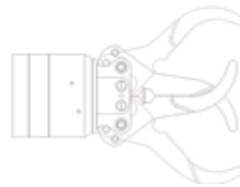

7.5" Three Finger Intermeshing



7.8" Four Finger Intermeshing



Dual TITAN manipulator configuration.

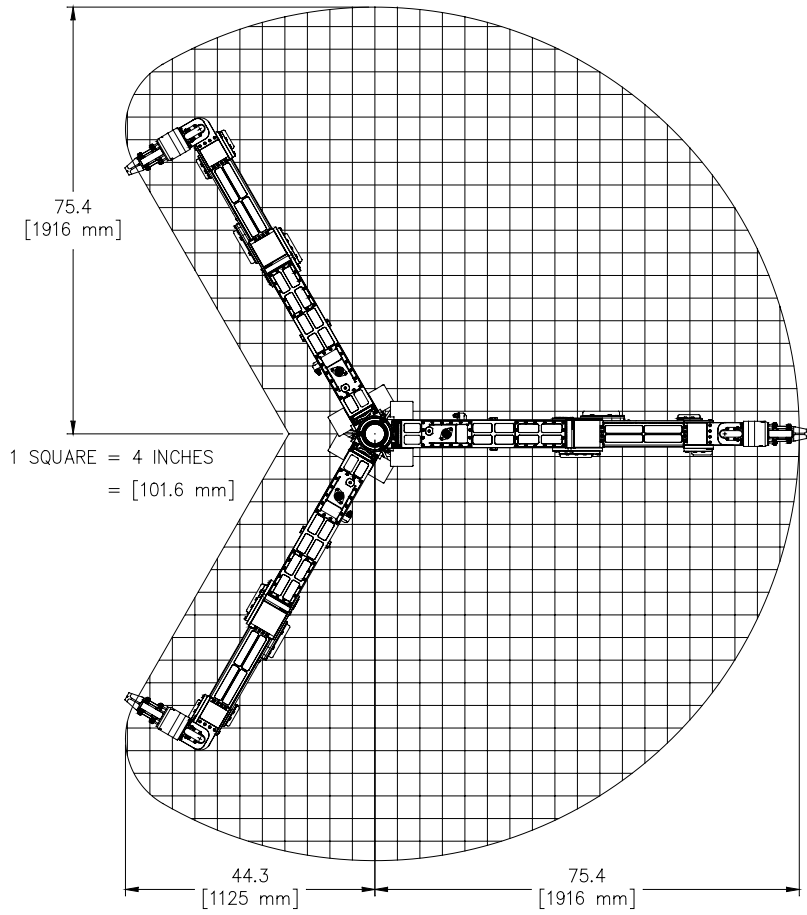

Range of Motion, Top View

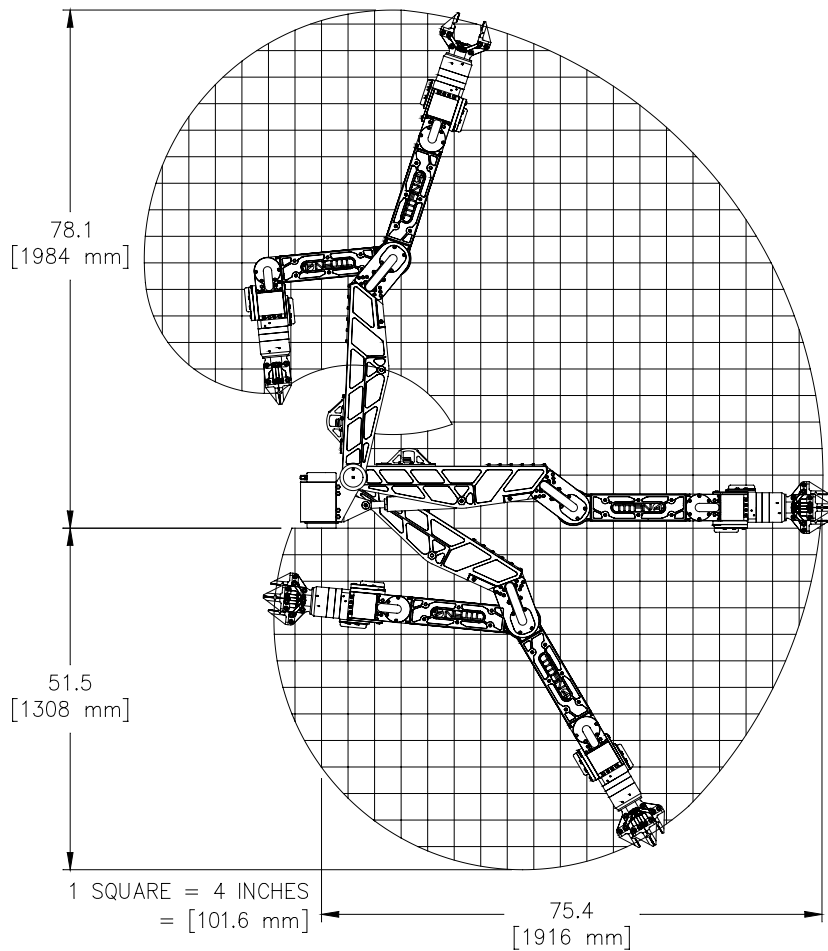

Range of Motion, Side View

We put you first.  
And keep you ahead.

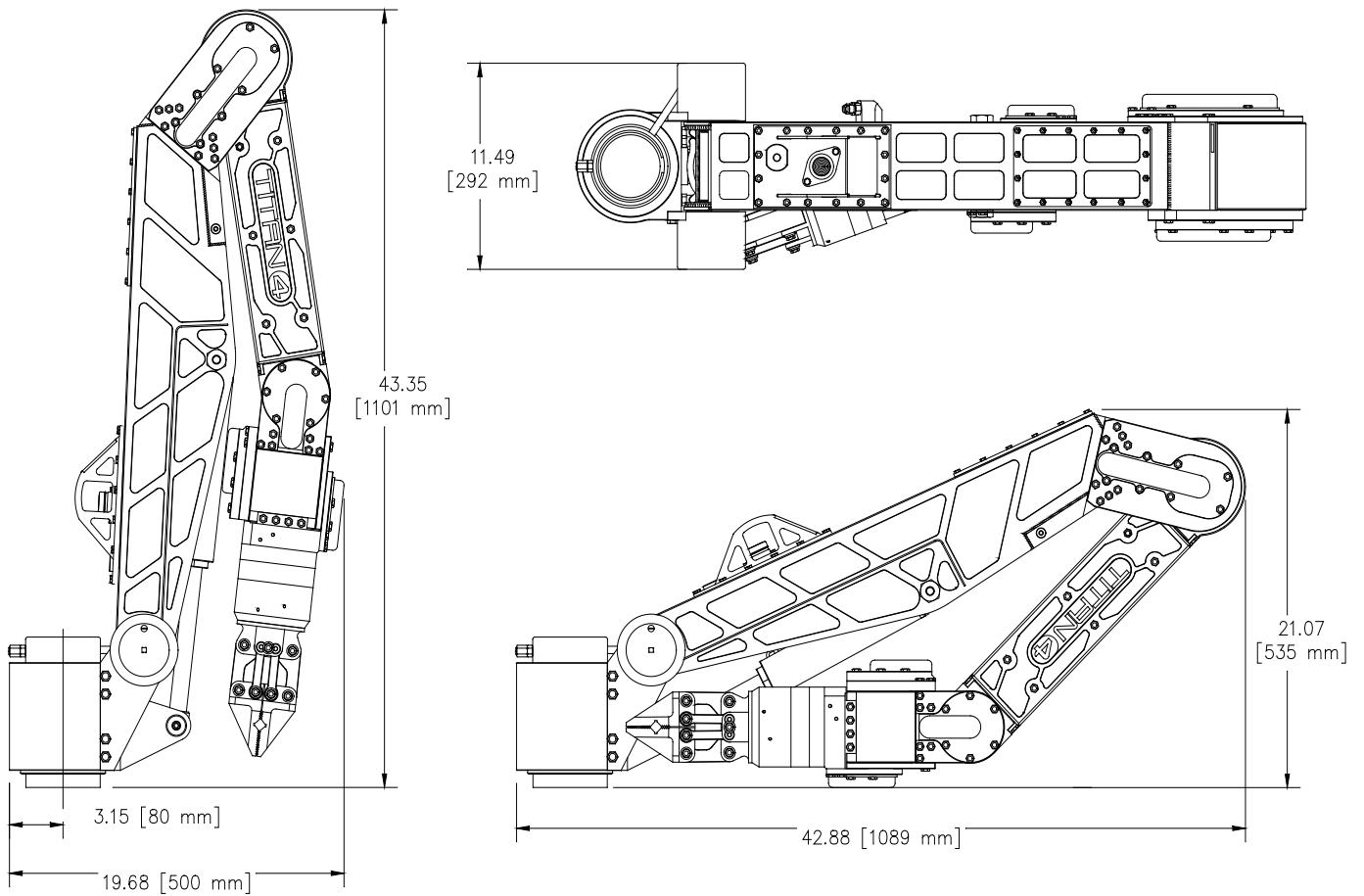

Stow Dimensions